

Change begins with **Innovation**



# PCL-15FT

## Inline Press-on & Screw-on Capper



- ◇ Three sets of capping spindles
- ◇ Ideal for feeding and securing caps to various shaped bottle ( round, oval, flat, rectangular, or square )

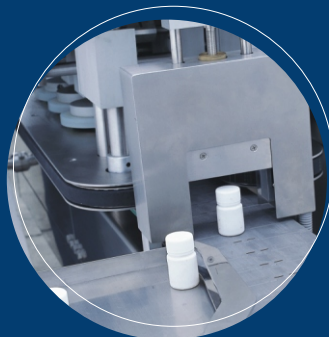

# PCL-15FT

## Operating Principle

The PLC-15FT is a versatile press-on and screw-on automatic capper, designed for the pharmaceutical, nutraceutical, food, beverage, and confection industries. The automatic rejection function rejects inverted caps to insure continuous product throughput. Its rugged stainless steel construction will fit seamlessly in your production line.

## Features

- PLC control with touch screen interface.
- Automatic failure analysis and real time alarm display.
- 304 stainless steel construction.
- Built-in flexibility to handle an array of product shapes and sizes.
- Automatic rejection of inverted caps.
- Optional rejection mechanism for “no cap” or “misapplied cap” available.
- Optional rejection mechanism for “no foil seal” available.
- Optional vibratory bowl cap feeder.



Option:  
Vibratory Cap Unscrambler

## Technical Specifications

Model	PCL-15FT
Max. speed	150 bpm
Bottle diameter	Square bottle: 25mm - 90 mm Round bottle: $\Phi$ 25 mm-90 mm
Bottle height	50mm - 150mm
Cap diameter	$\Phi$ 25 mm - 60 mm
Cap height	10mm - 30mm
Power supply	AC 220 V, 50-60 Hz, Single or Three Phase
Power absorption	1.25 KW
Air pressure	0.5~0.7 Mpa
Air consumption (dry, clear air)	Approx. 200 L/min
Dimensions (L x W x H) mm	2,581 x 1,300 x 2,150
Weight	Approx. 750 kg

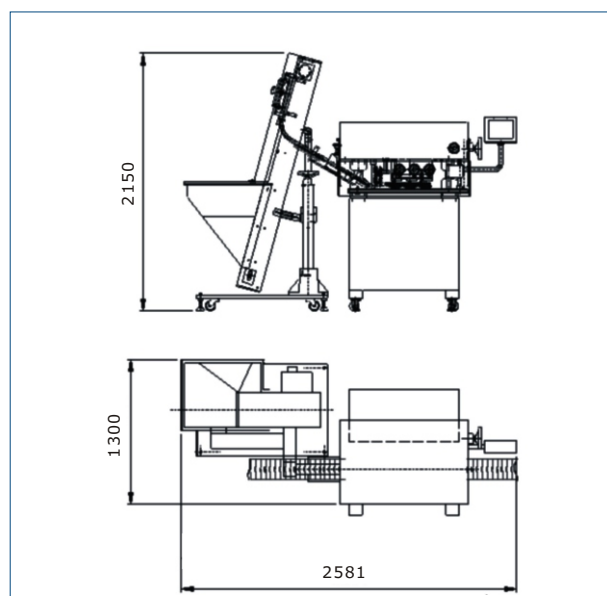

## PharmaPack-US

550 Burning Tree Road Fullerton, CA 92833 USA  
( 877) 727-2280 Toll Free (714) 526-0300 Fax  
sales@pharmapack-us.com www.pharmapack-us.com

*Exclusive Strategic Partner in The U.S. And Mexico*