

Change begins with **Innovation**

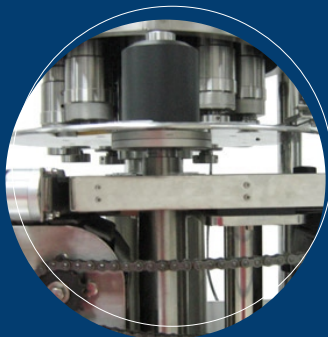

# PCR-2510

## Rotary Screw-on Capper



# PCRX-2510

## Operating Principle

The PCRX-2510 is a versatile Rotary screw-on automatic capper, designed for the pharmaceutical, nutraceutical, food, beverage, and confection industries. The automatic rejection function rejects inverted caps to insure continuous product throughput. A star wheel and cam combine to place caps accurately onto the bottles and adjustable torque settings insure that all bottles are capped consistently. Its rugged stainless steel construction will fit seamlessly in your production line.

## Features

- PLC control with touch screen interface.
- Automatic failure analysis and real time alarm display.
- 304 stainless steel construction.
- Built-in flexibility to handle an array of product shapes and sizes.
- Automatic rejection of inverted caps.
- 10 capping heads.
- Adjustable torque settings.
- Optional rejection mechanism for “no cap” or “misapplied cap” available.
- Optional rejection mechanism for “no foil seal” available.

## Technical Specifications

Model	PCTV-2510
Max. speed	250 bpm
Cap size	Φ20 mm-70 mm
Bottle dia.	Φ20 mm-70 mm
Bottle height	45 mm - 120 mm
Power supply	AC 220 V, 50-60 Hz, Single or Three Phase
Power absorption	1.69 kW
Air pressure	0.5~0.7 mpa
Air consumption	85 L/min clear air
Dimension (L x W x H) mm	3,100 x 2,400 x 2,150
Weight	Approx. 2,000 kg

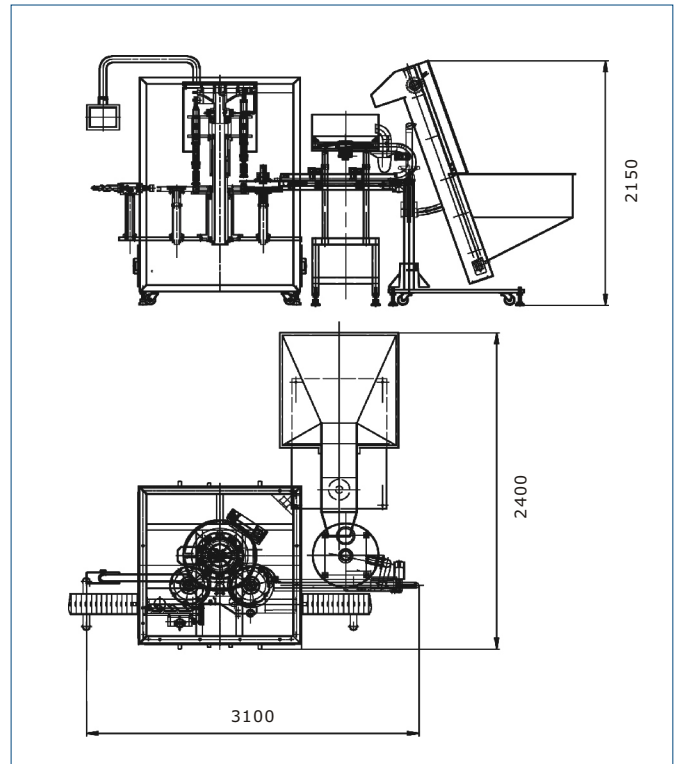

## PharmaPack-US

550 Burning Tree Road Fullerton, CA 92833 USA  
(877) 727-2280 Toll Free (714) 526-0300 Fax  
sales@pharmapack-us.com www.pharmapack-us.com

*Exclusive Strategic Partner in The U.S. And Mexico*