

Change begins with **Innovation**

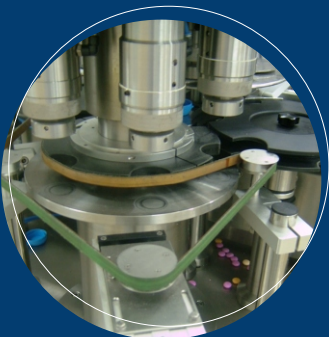

PCT-1506

Rotary Press-on Capper



PCT-1506

Bottles filled with material, line a row to be conveyed to the bottle transmitting screw device by conveyor. After bottles are parted to keep a certain space, they are transmitted to the bottle entering star wheel exactly. And at the same time, caps are elevated from storage hopper to cap unscrambling device by elevator. The cap unscrambling device automatically unscrambles caps according to the cap direction, to convey the right caps to cap sliderail and enter the cap transmitting star wheel. After the crowner head of every cap pressing axis (6 heads) in the cam device of main machine catches cap (holding cap in vacuum state), caps descend along with the movement of the cap pressing axis to gradually be kept on the bottle mouth, and then to enter the main star wheel to press cap. Capped bottles are transferred onto the conveyor by the bottle exiting star wheel. After the rejection device detects bottles (automatically reject bottles with no aluminum foil or poor capping), they are conveyed to the next working procedure by conveyor.

Features

- Automatically unscramble and output caps with the pros and cons direction, with high automatization.
- With function of automatically rejecting bottles with no aluminum foil or poor capping (optional fittings)
- With the dynamic display function of touch screen, operation is easy, interface is good, the relevant parameters can be adjusted in real time.
- Automatically diagnose the failure, and have the real-time acousto-optical alarm and display system.
- With power overloading safety protection, and operation is safe.

Technical Specifications

Model	PCT-1506
Max.speed	150 bpm
Bottle diameter	Φ20 mm - 65 mm
Bottle height	45 mm - 120 mm
Cap diameter	Φ20 mm - 60 mm
Cap height	10 mm - 30 mm
Power supply	AC 380 V, 50/60 Hz, Single or ThreePhase
Power absorption	2.92 kW
Air pressure	0.5~0.7 mpa
Air consumption (dry, clean air)	80 L/min
Dimensions (L x W x H) mm	2,900 x 1,900 x 2,550
Weight	Approx. 1300 kg

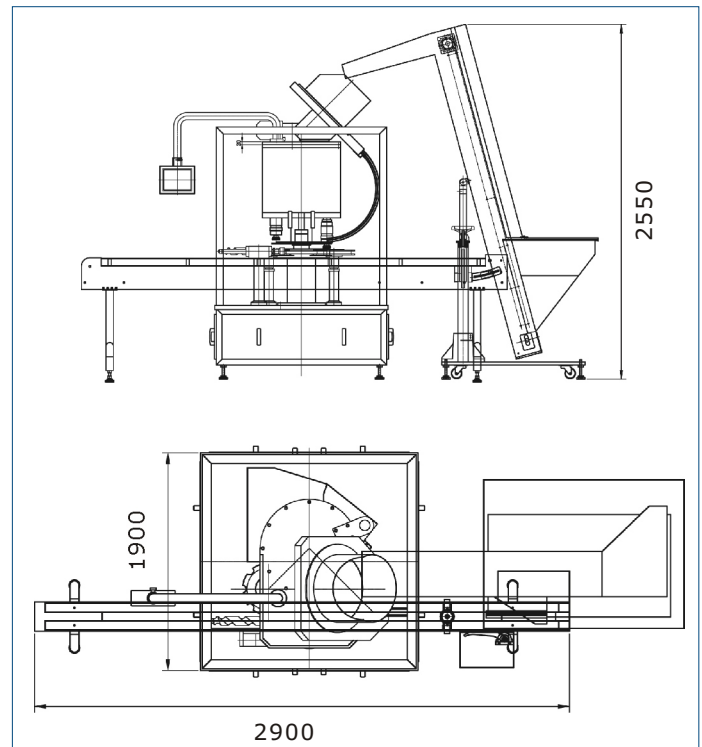

PharmaPack-US

550 Burning Tree Road Fullerton. CA 92833 USA
 (877) 727-2280 Toll Free (714) 526-0300 Fax
 sales@pharmapack-us.com www.pharmapack-us.com

Exclusive Strategic Partner in The U.S. And Mexico