

Change begins with Innovation



PP-16

Tablet/Capsule Counter



◇ 32 channels ,every 16 channels with double drop funnels to ensure high speed performance



PP-16

Operating Principle

Tablets of all shapes, hard shell capsules, and soft gelatin capsules are moved by vibration over a three-tiered channel section from which they free fall through an infrared beam using a photo electric sensor to count each tablet/capsule. The counting of these products and the indexing of the bottle to be filled is controlled by a high speed MCU board.

Features

- Photoelectric recognition of the product ensures the accuracy of count and recognition of partial products. When counting uncoated tablets the sophisticated photoelectric sensor can determine when the lens is becoming "clouded" and emits an alarm allowing the operator to clean the lens to prevent an over count situation.
- Multiple vacuum ports promote a clean operation.
- No tools are required to change over or clean the counter.
- If a failure occurs the self-diagnostic system will emit an alarm and display the fault on the touch screen in real-time.
- "No bottle" sensor and "back up" bottle sensor can alert the controller which will stop the counter until the problem is corrected.
- The controller has the capability to recognize the shape of a product and set operating parameters.
- High quality Festo cylinders are used to reduce downtime.
- The Pro-face touch screen is user-friendly and offers World-wide support.

Technical Specifications

Model	PP-12
Max.Speed	12,000 pcs/min
Dosage/btl	1~1,000 pcs
Tablet size (mm)	Thickness: 3~10 Dia: 3-13 Length: 3-21 Applicable to tablets,capsules,caplets,soft gels, transparent soft capsules etc.
Bottle size (mm)	Dia: 20~100 Height: 40~240
Power supply	AC 220 V, 50-60 Hz, Single or Three Phase
Power absorption	4.2 kW
Air pressure	0.5~0.7 Mpa
Air consumption	260 L/min clear air
Dimension:LXWXH(mm)	1,980 x 1,870 x 1,740
Weight	Approx. 1,000 kg

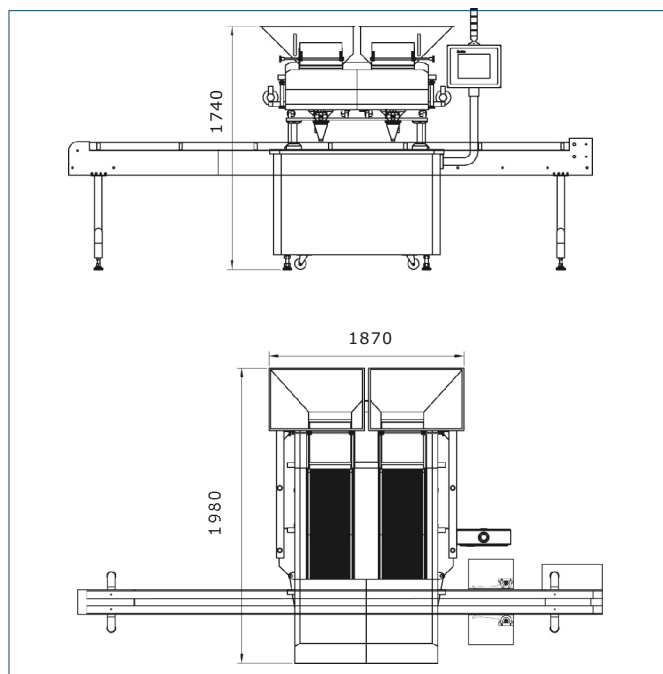

PharmaPack-US

550 Burning Tree Road Fullerton. CA 92833 USA
(877) 727-2280 Toll Free (714) 526-0300 Fax
sales@pharmapack-us.com www.pharmapack-us.com

Exclusive Strategic Partner in The U.S. And Mexico